

REVISION DATA				
REV	ECN No.	DESCRIPTION	NAME	DATE
A0		NEW DRAWING	Songjun	2020-09-17

CUSTOMER USES  
PULL OUT DIRECTION  
→

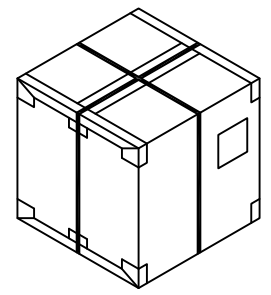
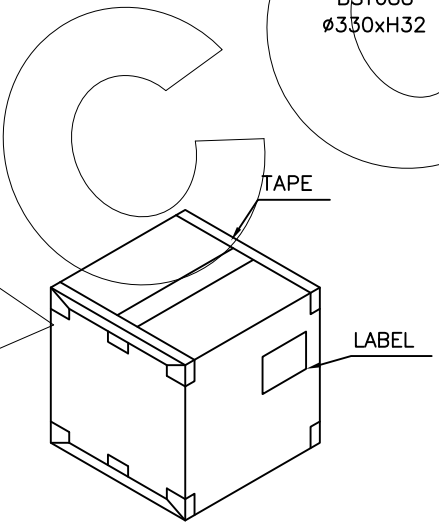
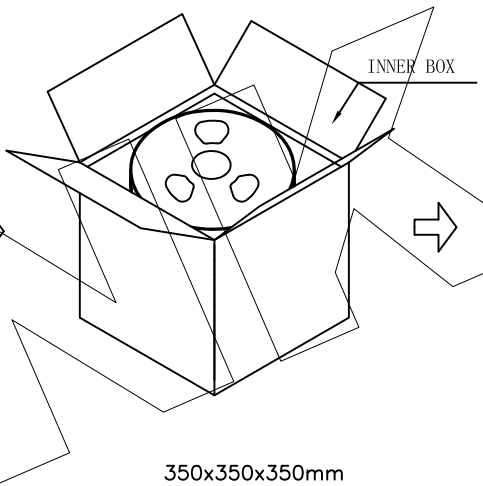
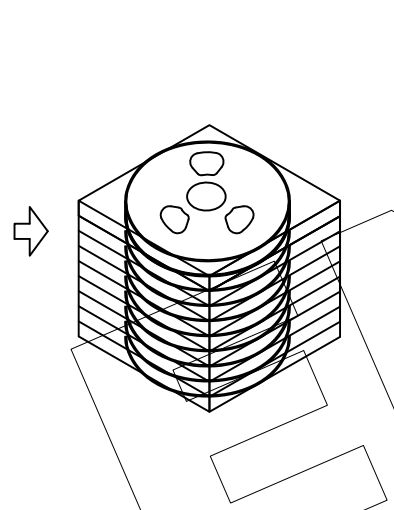
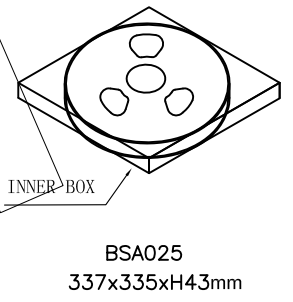
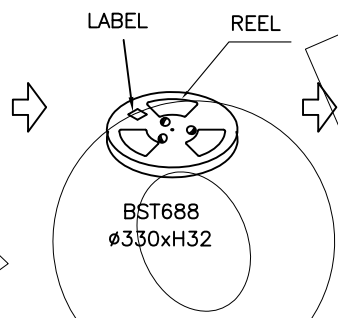
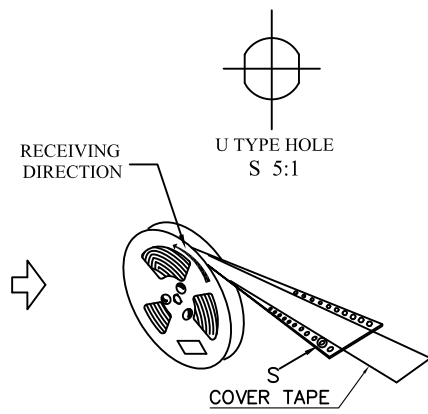
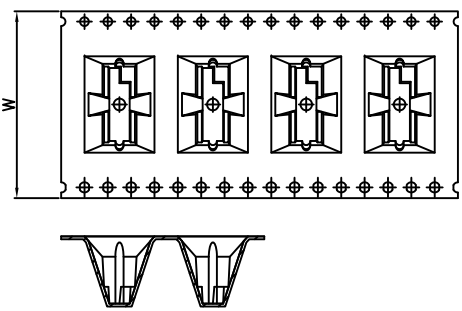

PACKAGE DESCRIPTION:  
 STEP 1: PUT THE FINISHED PRODUCT INTO THE REEL OF REEL, AND LABEL EACH ROLL  
 STEP 2: PUT THE REEL INTO THE VACUUM BAG, REMOVE THE VACUUM, AND THEN PUT IT INTO THE INNER BOX.  
 STEP 3: FOLD THE INNER BOX AND PUT IT INTO AN OUTER BOX  
 STEP 4: SEAL THE BOX WITH ADHESIVE TAPE  
 STEP 5: LABEL THE UPPER RIGHT CORNER OF THE UPPER SIDE OF THE OUTER BOX  
 STEP 6: PACK THE TIE

Quantity:

Reel/PCS	INNER BOX/PCS	INNER BOX/BOX	BOX/PCS
XXX	XXX	XX	XXXX

**ENKCOM®** 东莞市恩康电子科技有限公司  
 www.enkcom.com  
 TEL:+86(0)769 8904 9672  
 FAX:+86(0)769 8904 9671  
 E-MAIL:sales@anycom.tw  
**DONGGUAN ENKANG ELECTRONICS TECHNOLOGY CO.,LTD**

TOLERANCE ANGLE ±5° X.XXX ±0.10 X.XX ±0.20 X.X ±0.30 X. ±0.50	DATE :	2020-09-17	TITLE: PH1.00 H1.50mm Pin Header-REEL PACKING			
	DRAWN :	Songjun	PART NO: P136XXXXXXXXXXXXXX			
	CHECKED :					
	APPROVED :					
PROJECTON		REV: A0	UNIT: mm	SCALE: 1:1	SIZE: A4	PAGE: 1/1