

REVISION DATA		
REV	DESCRIPTION	DATE
A0	NEW DRAWING	2015-05-21

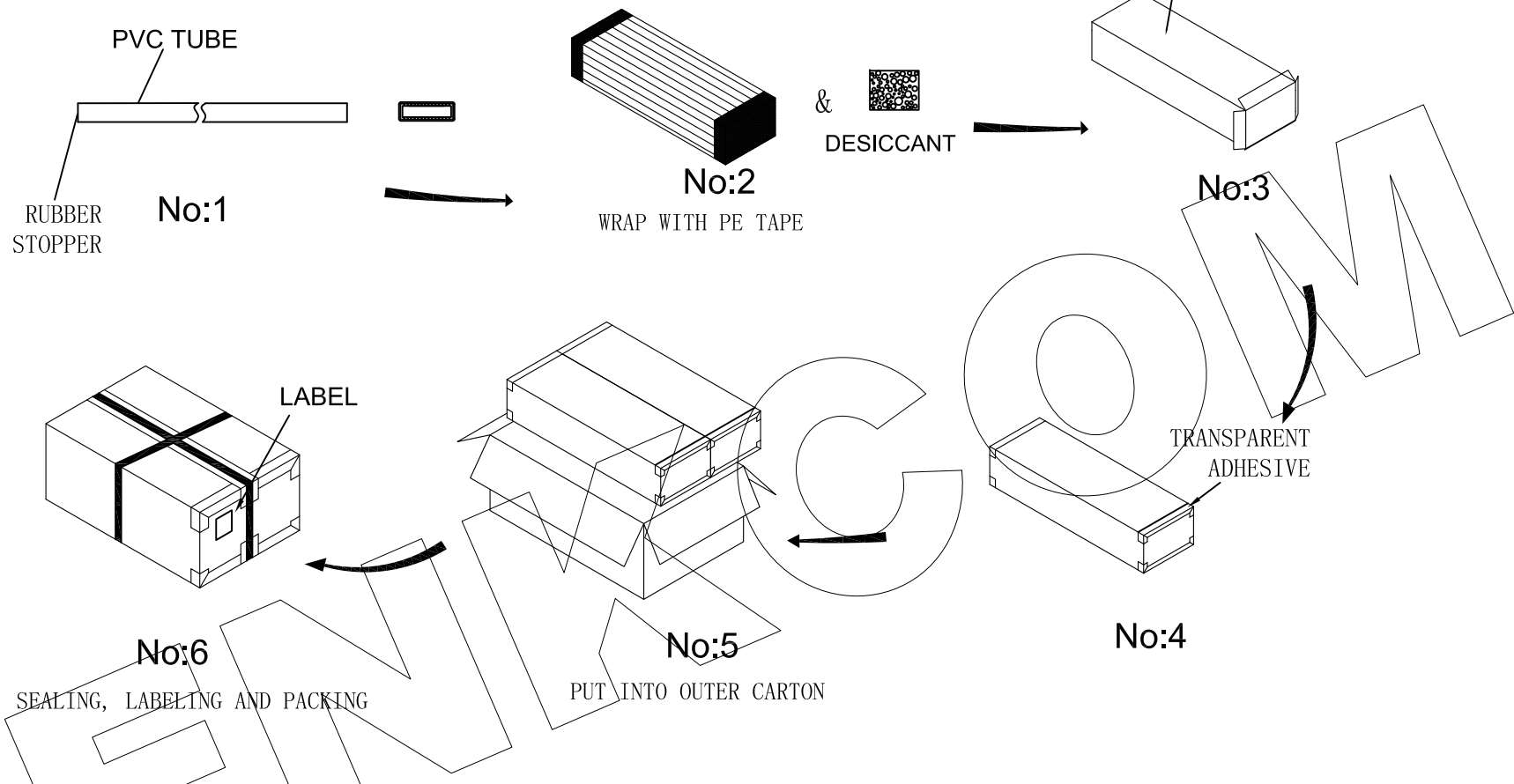

PACKAGE DESCRIPTION:
 STEP 1: PUT THE TESTED PRODUCT INTO THE PVC TUBE, AND THEN GLUE THE PVC TUBE PLUG AND SEAL
 STEP 2: WRAP THE PVC TUBE WITH PE FILM AND PUT IN DESICCANT
 STEP 3: PUT THE WRAPPED PVC TUBE INTO THE INNER BOX.
 STEP 4: SEAL THE INNER BOX WITH TRANSPARENT GLUE
 STEP 5: SEAL THE SEALED INNER CASE AND OUTER BOX.
 STEP 6: SEAL THE OUTER BOX WITH TRANSPARENT GLUE AND LABEL THE OUTER BOX. THEN BANDAGE TAKE A BANDAGE.

PART No.	PIPE/pcs	BOX/PIPE
F113XXXXXXXXXXXXXXXX	XX	XXX

ENKCOM® 东莞市恩康电子科技有限公司
 www.enkcom.com
 TEL:+86(0)769 8904 9672
 FAX:+86(0)769 8904 9671
 E-MAIL:sales@anycom.tw
DONGGUAN ENKANG ELECTRONICS TECHNOLOGY CO.,LTD

TOLERANCE ANGLE ±5° X.XXX ±0.10 X.XX ±0.20 X.X ±0.30 X. ±0.50	DATE :	2015-05-21	TITLE: PH1.27 H2.1 Female Header-Tube Packing			
	DRAWN :	Songjun	PART NO: F113XXXXXXXXXXXXXXXX			
	CHECKED :					
	APPROVED :					
PROJECTON		REV: A0	UNIT: mm	SCALE: 1:1	SIZE: A4	PAGE: 1/1