

REVISION DATA				
REV	ECN No.	DESCRIPTION	NAME	DATE
A0		NEW DRAWING	Songjun	2017-09-09

CUSTOMER USES
PULL OUT DIRECTION

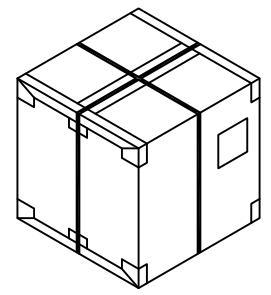
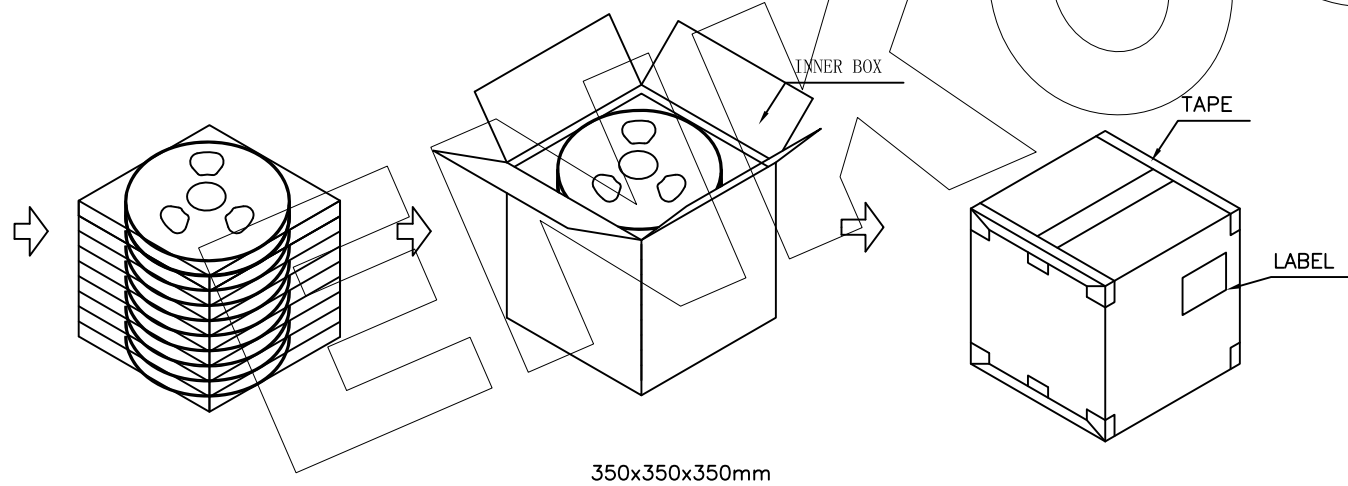
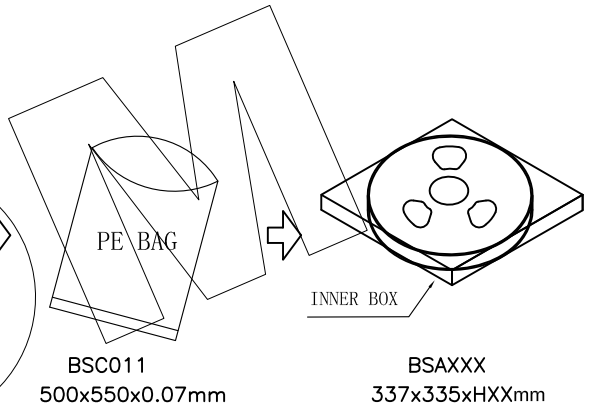
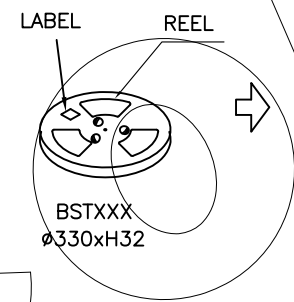
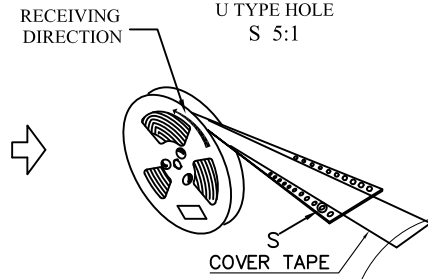
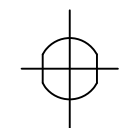
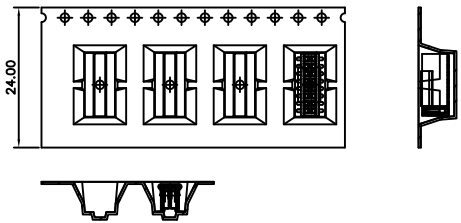

PACKAGE DESCRIPTION:
 STEP 1: PUT THE FINISHED PRODUCT INTO THE REEL OF REEL, AND LABEL EACH ROLL
 STEP 2: PUT THE REEL INTO THE VACUUM BAG, REMOVE THE VACUUM, AND THEN PUT IT INTO THE INNER BOX.
 STEP 3: FOLD THE INNER BOX AND PUT IT INTO AN OUTER BOX
 STEP 4: SEAL THE BOX WITH ADHESIVE TAPE
 STEP 5: LABEL THE UPPER RIGHT CORNER OF THE UPPER SIDE OF THE OUTER BOX
 STEP 6: PACK THE TIE

Quantity:

Reel/PCS	INNER BOX/PCS	INNER BOX/BOX	BOX/PCS
XXX	XXX	XX	XXXX

ENKCOM® 东莞市恩康电子科技有限公司
 www.enkcom.com
 TEL:+86(0)769 8904 9672
 FAX:+86(0)769 8904 9671
 E-MAIL:sales@anycom.tw

DONGGUAN ENKANG ELECTRONICS TECHNOLOGY CO.,LTD

TOLERANCE	DATE :	2017-09-09	TITLE:	
	ANGLE ±5°	DRAWN :	PH1.27 H4.30 Female Header-Reel Packing	
	X.XXX ±0.10	CHECKED :	PART NO: F136XXXXXXXXXXXXXX	
X.XX ±0.20	APPROVED :			
X.X ±0.30	PROJECTON		REV: A0	UNIT: mm
X. ±0.50			SCALE: 1:1	SIZE: A4
			PAGE: 1/1	