

4

3

2

1

## REVISION DATA

REV	DESCRIPTION	DATE
A0	NEW DRAWING	2017-11-13

卷带拉出使用方向

卷带收料方向

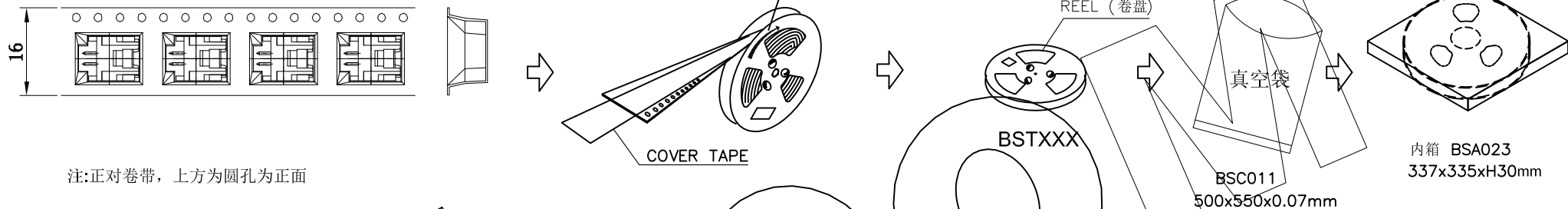

注:正对卷带,上方为圆孔为正面

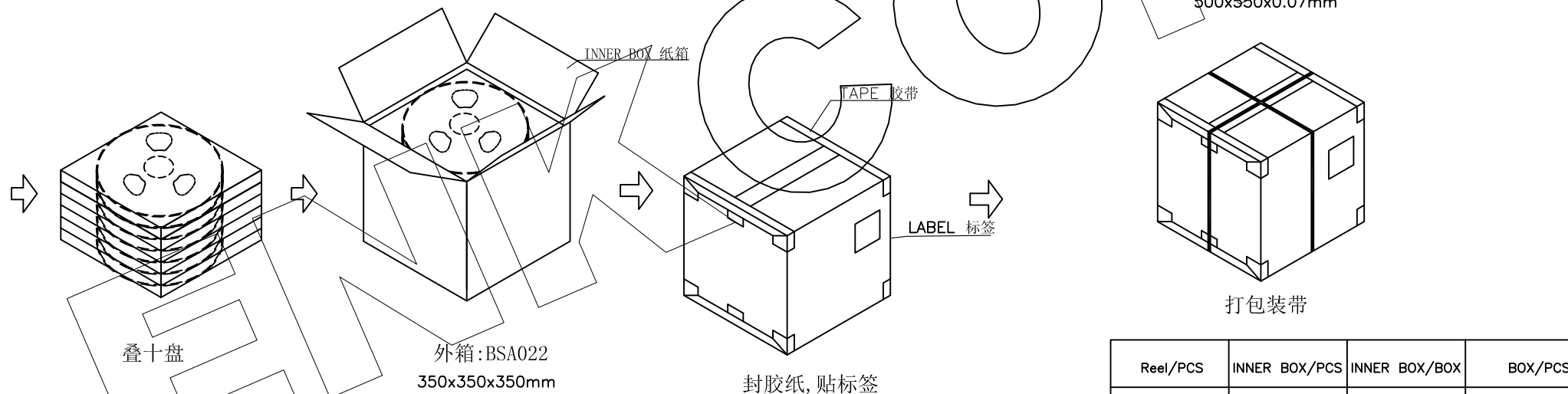

## 包装说明:

步骤1: 将检验好的成品Dip朝下放入REEL卷带内,每卷装800PCS,前空20PCS,后空15PCS,每卷需贴上标签.

步骤2: 将卷盘装入真空袋,然后装入内箱.

步骤3: 十盘内箱叠好放入一个外箱.

步骤4: 封箱贴胶子.

步骤5: 在外箱上填写产品品名,数量,重量,并贴上QC标签.

步骤6: 打包装袋

Reel/PCS	INNER BOX/PCS	INNER BOX/BOX	BOX/PCS
800	800	10	8000

Noted:卷带前空16PCS 后空17PCS

ENKCOM 东莞市恩康电子有限公司

www.enkcom.com

DONGGUAN ENKANG ELECTRONICS CO.,LTD

TOLERANCE	PROJECTON		TITLE:
ANGLE ±5°	DATE:	2017-11-13	WAFER PH2.0 H9.2 1*2Pin 卧式SMT
X.XXX ±0.10	DRAWN:	Zhang	卷装包装规范
X.XX ±0.20	CHECKED:		PART NO: WFBH002XXXNH003
X.X ±0.30	APPROVED:		DRAWING NO:
X. ±0.50			REV: A0 UNIT: mm SCALE: 1:1 SIZE: A4