

4

3

2

1

## REVISION DATA

REV	DESCRIPTION	DATE
A0	NEW DRAWING	2016-03-14

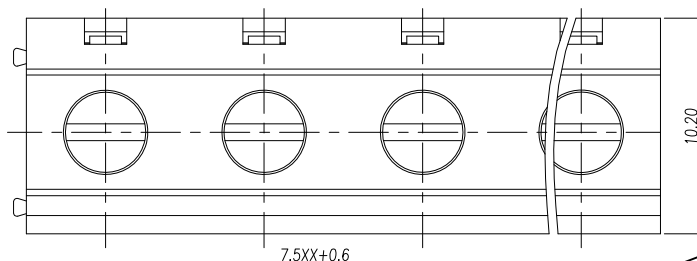
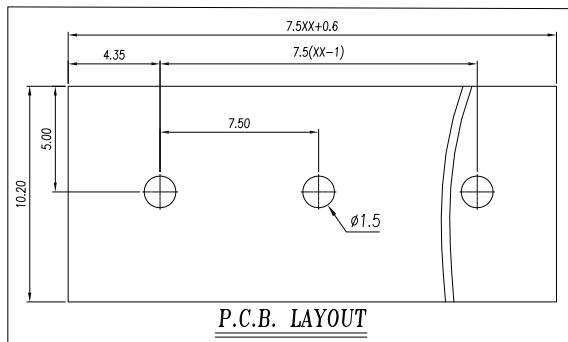

参考标准/Standard	UL	IEC
额定电压/Rated voltage	300V	450V
额定电流/Rated current	16A	20A
接触电阻/Contact resistance	20mΩ	
绝缘电阻/Insulation resistance	500MΩ/DC500V	
使用线径/Wire range	22~12AWG	2.5mm <sup>2</sup>
耐电压/Wrth standing voltage	AC 2000V/1 Min	
机械性能/Mechanical		
扭矩/Torque	0.4Nm(3.6Lb.in)	
剥线长度/Steip Length	6-7mm	
温度范围/Temp.Range	-40°C~+105°C	
瞬时温度/MAX Soldering	+250°C, for 5 Sec	

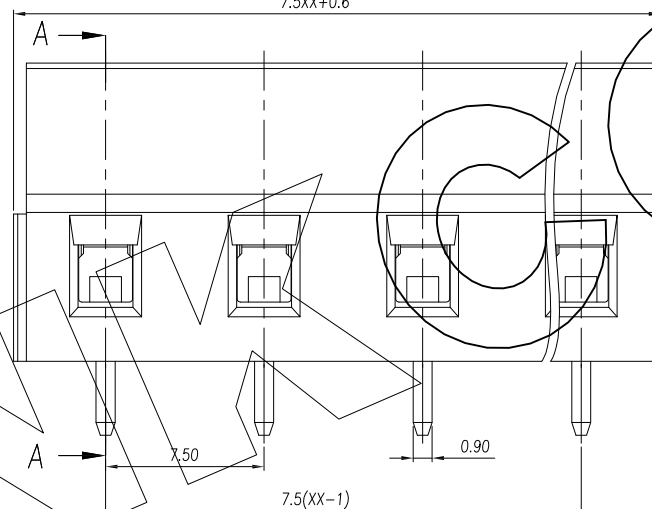
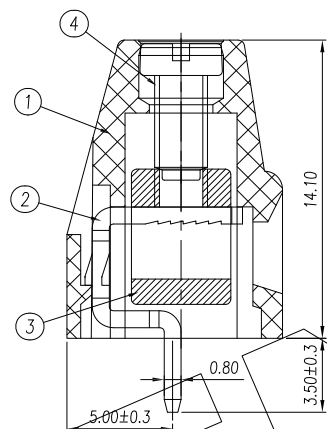

## 尺寸/Dimensions

间距/Pitch	7.5mm
极数/Poles	2~24p

## 材质及电镀/Material

塑件/Housing	PA66, UL94V-0
螺丝/Screws	M2.5 Steel Zn plated
焊脚/Pin header	Brass 0.8t Tin plated
方块/Cage	Brass Ni plated

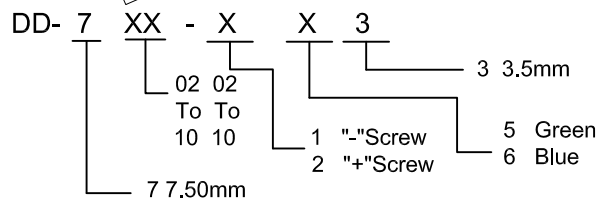

ENKCOM® 东莞市恩康电子有限公司

www.enkcom.com

DONGGUAN ENKANG ELECTRONICS CO.,LTD

TOLERANCE	PROJECTON		TITLE:
ANGLE ±5°	DATE :	2016-03-14	DD Pitch 7.5mm Series
X.XXX ±0.15	DRAWN :	Songjun	PART NO: DD7XX1X3A
X.XX ±0.20	CHECKED :		
X.X ±0.30	APPROVED :		REV: A0
X. ±0.50			UNIT: mm
			SCALE: 1:1
			SIZE: A4

4

3

2

1