

REVISION DATA				
REV	ECN No.	DESCRIPTION	NAME	DATE
A0		NEW DRAWING	S.J	2023-05-20

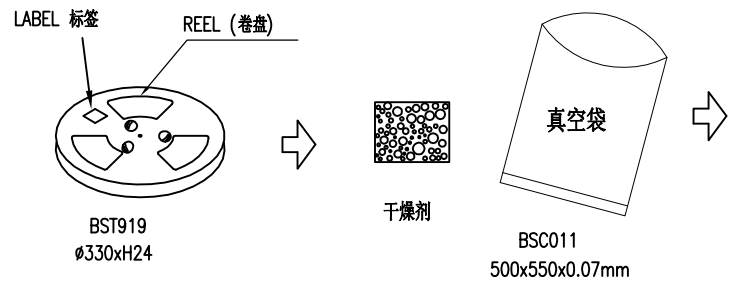

注:正对卷带,上方为圆孔,下方无孔为正面
卷带/卷盘/上带材质: PS(透明色)/PS(蓝色)/PET(透明色)
剥离力标准:10~100g

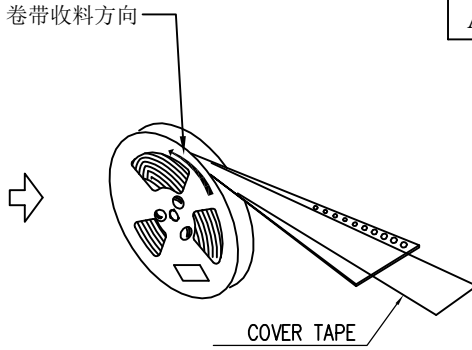
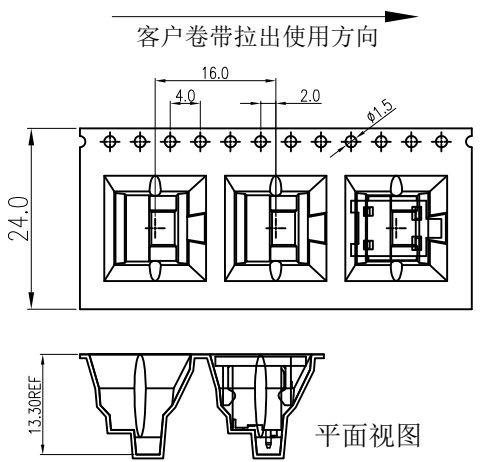
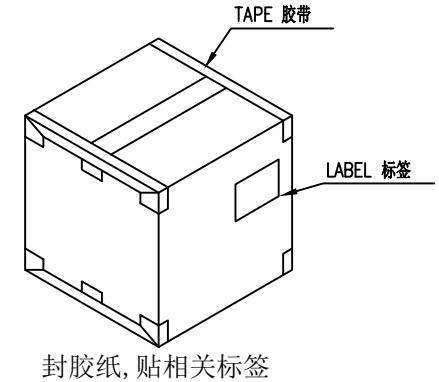
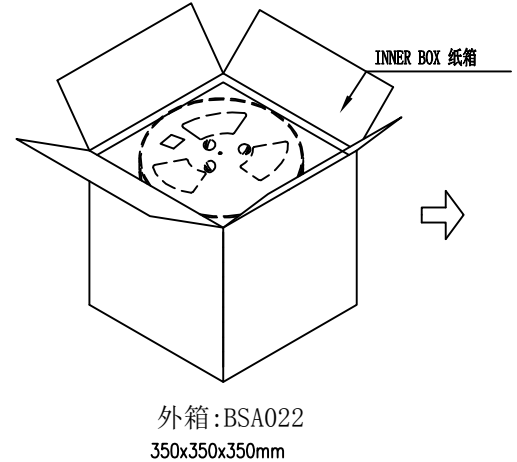
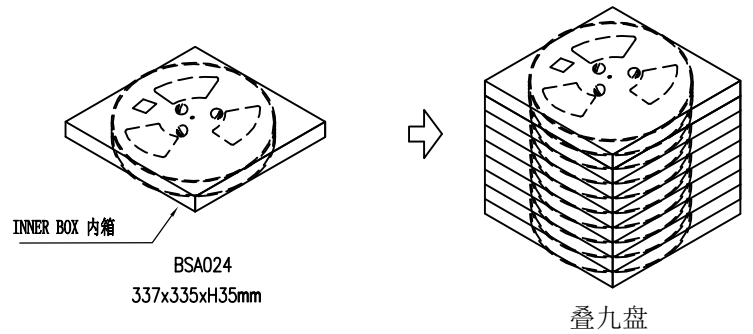

Quantity:

Reel/PCS	INNER BOX/PCS	INNER BOX/BOX	BOX/PCS
300	300	9	2700

Noted:卷带前空12PCS, 后空12PCS

- 包装说明:
- 步骤1: 将检验好的成品Dip朝下放入REEL卷带内,每卷装300PCS,每卷需贴上标签.
 - 步骤2: 将卷盘装入真空袋,吸去真空,放入1PCS干燥剂,然后装入内箱.
 - 步骤3: 九内箱叠好放入一个外箱.
 - 步骤4: 封箱贴好胶纸.
 - 步骤5: 在外箱上侧面右上角贴上相关标签.
- 注意: 如客户有特殊要求, 依客户要求包装.

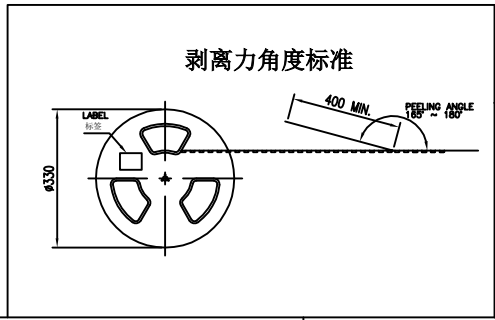

ANYCONN® 东莞市恩康电子科技有限公司
DONGGUAN ENKANG ELECTRONIC TECHNOLOGY CO.,LTD

www.enkcom.com
TEL:+86(0)769 8904 9672
FAX:+86(0)769 8904 9671
E-MAIL:sales@anycom.tv

TOLERANCE	DATE :	2023-05-20	TITLE:		
ANGLE ±2°	DRAWN :	S.J	电源连接器PH3.0/PH1.0 180度+SMT 有柱 有CAP 卷带包装规范		
X.XXX ±0.10	CHECKED :		PART NO: WFFT11008XXXXWTA01		
X.XX ±0.20	APPROVED :		REV: A0	UNIT: mm	SCALE: 1:1
X.X ±0.25	PROJECTION		SIZE: A4	PAGE: 1/1	
X. ±0.30					