

REVISION DATA				
REV	ECN No.	DESCRIPTION	NAME	DATE
A0		NEW DRAWING	JQSUN	2023-04-20

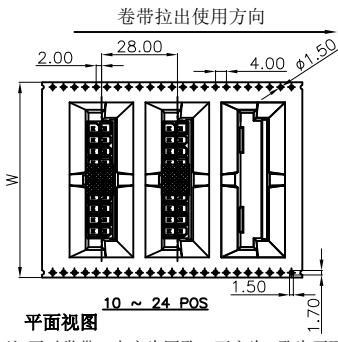

平面视图
注:正对卷带,上方为圆孔,下方为U孔为正面
卷带/卷盘/上带材质: PS(黑色)/PS(蓝色)/PET(透明色)
剥离力标准:20~130g

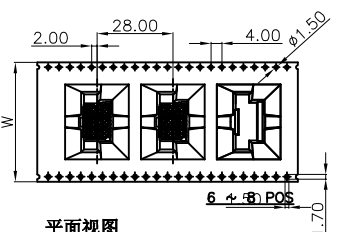

平面视图
注:正对卷带,上方为圆孔,下方为U孔为正面
卷带/卷盘/上带材质: PS(黑色)/PS(蓝色)/PET(透明色)
剥离力标准:20~130g

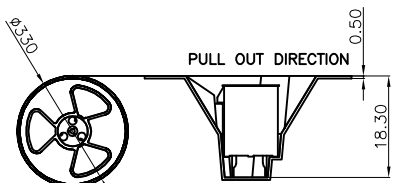
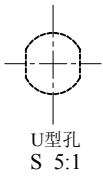

卷带收料方向

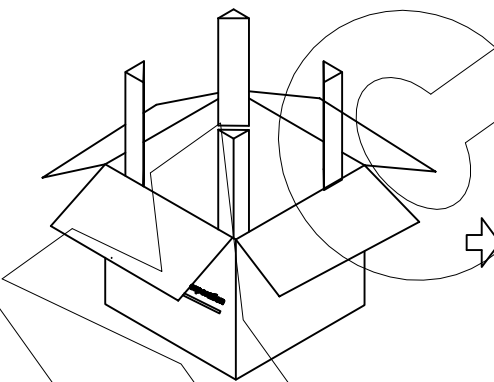
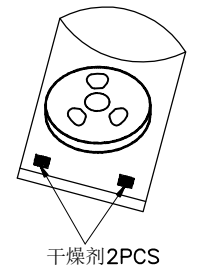
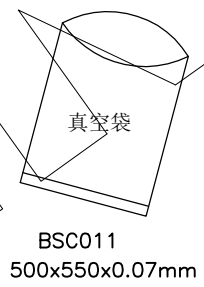
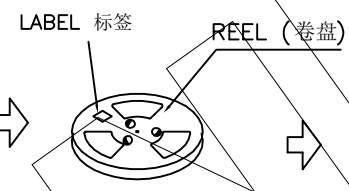
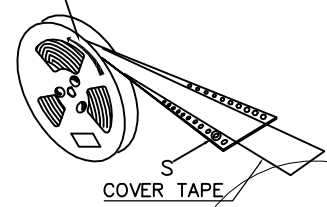

外箱: (L350xW350xH350mm)
外箱: (L350xW350xH270mm)

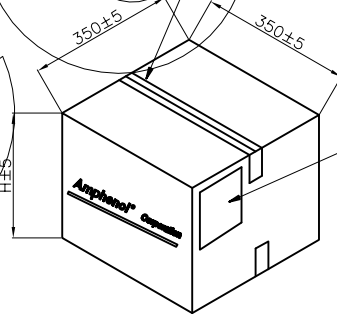

密封胶纸, 贴相关标签

包装说明:
步骤1: 将检验好的成品Dip朝下放入REEL卷带内,每卷装100PCS,前后各空10PCS,每卷需贴上标签.
步骤2: 将2PCS干燥剂放入真空袋,
步骤3: 将卷盘装入真空袋,吸去真空.
步骤4: 叠好放入一个外箱,(箱内上、下各放1PCS隔板).
步骤5: 封箱贴好胶纸.
步骤6: 在外箱上侧面右上角贴上相关标签.
注意: 如客户有特殊要求,依客户要求包装.

POS.	W	H	QUANTITY (PCS)	REELS CARTON	PCS REEL
06	44.0	270	500	5	100
08			500	5	100
10	56.0	270	400	4	100
12			400	4	100
14			400	4	100
16			300	3	100
18	72.0	270	300	3	100
20			300	3	100
22			300	3	100
24	88.0	350	300	3	100

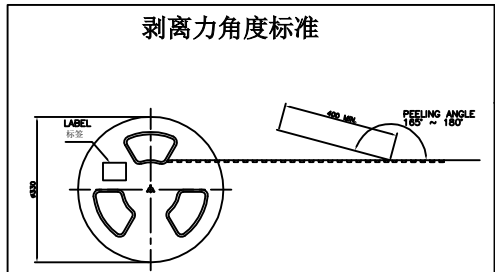

ANYCONN®
www.enkcom.com
TEL:+86(0)769 8904 9672
FAX:+86(0)769 8904 9671
E-MAIL:sales@anyconn.tw

东莞市恩康电子科技有限公司
DONGGUAN ENKANG ELECTRONICS TECHNOLOGY CO.,LTD

TOLERANCE	DATE: 2023-04-20	TITLE: Mini Power PH4.20 HI2.8 180度 PH28.00mm卷带包装规范
ANGLE ±5°	DRAWN: JQSUN	PART NO:WFJD12XXXXXXXDX17
X.XXX ±0.15	CHECKED:	
X.XX ±0.25	APPROVED:	
X.X ±0.35	PROJECTON	REV: A0 UNIT: mm SCALE: 1:1 SIZE: A4 PAGE: 1/1
X. ±0.50		