

REVISION DATA				
REV	ECN No.	DESCRIPTION	NAME	DATE
A0		NEW DRAWING	D.Y.Y	2023-03-24

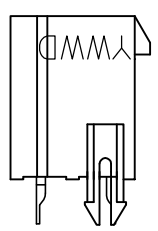

产品

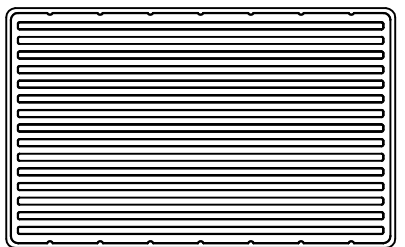

吸塑盘 426x262.5x8mm

No:1

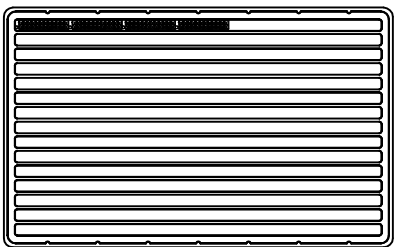

吸塑盘上盖 426x262.5x19mm

No:2

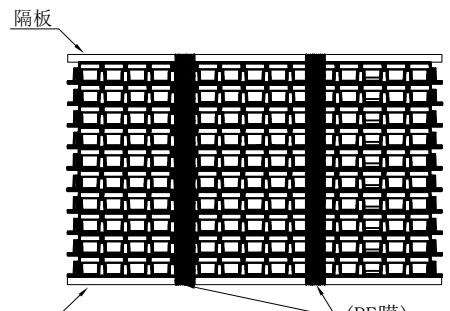

10盘叠好捆PE膜

No:3

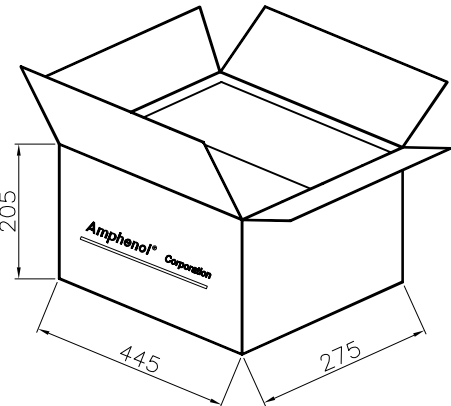

No:4
装入外箱(10盘/外箱)
445x275x205mm

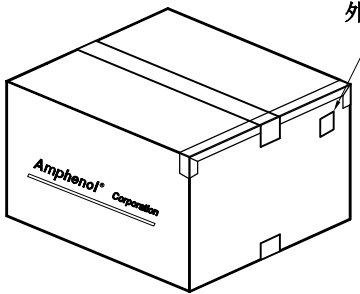

No:5
封箱、贴外箱标签

Part No.	Pin位数	PCS/TRAY	PCS/CARTON
WFJD12002XXXXDX19	2x1P	705	7050
WFJD12004XXXXDX19	2x2P	465	4650
WFJD12006XXXXDX19	2x3P	345	3450
WFJD12008XXXXDX19	2x4P	285	2850
WFJD12010XXXXDX19	2x5P	240	2400
WFJD12012XXXXDX19	2x6P	195	1950
WFJD12014XXXXDX19	2x7P	180	1800
WFJD12016XXXXDX19	2x8P	150	1500
WFJD12018XXXXDX19	2x9P	135	1350
WFJD12020XXXXDX19	2x10P	120	1200
WFJD12022XXXXDX19	2x11P	120	1200
WFJD12024XXXXDX19	2x12P	105	1050

包裝說明:

- 步驟1: 將檢驗好之产品 DIP脚朝上摆入真空盘 (注意未滿一格時需加塞泡棉条以避免产品翻盘)
- 步驟2: 將真空盘上盖盖在真空盘上.
- 步驟3: 將裝好产品的真空盘每10盘叠好, 上下两个面分別加隔板, 用PE薄膜缠绕固定绑好.
- 步驟4: 將裝好产品的真空盘放入PE防水袋中, 放入2PCS干燥剂, 扎好袋口后放入外箱内.
- 步驟5: 用透明胶把外箱封好并在外箱上贴上标签.

ANYCONN® 东莞市恩康电子科技有限公司
 www.enkcom.com
 TEL:+86(0)769 8904 9672
 FAX:+86(0)769 8904 9671
 E-MAIL:sales@anycom.tw
DONGGUAN ENKANG ELECTRONICS TECHNOLOGY CO.,LTD

TOLERANCE	DATE :	2023-03-24	TITLE: Mini Power PH4.20 H12.8 180度 盘装包规		
ANGLE ±5°	DRAWN :	D.Y.Y			
X.XXX ±0.10	CHECKED :		PART NO: WFJD12XXXXXXXXDX19		
X.XX ±0.20	APPROVED :				
X.X ±0.30	PROJECTON				
X. ±0.50	REV: A0	UNIT: mm	SCALE: 1:1	SIZE: A4	PAGE: 2/2

REVISION DATA				
REV	ECN No.	DESCRIPTION	NAME	DATE
A0		NEW DRAWING	JQSUN	2023-04-20

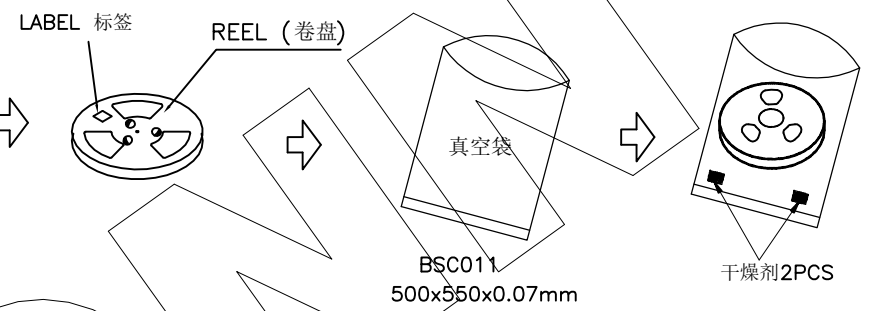
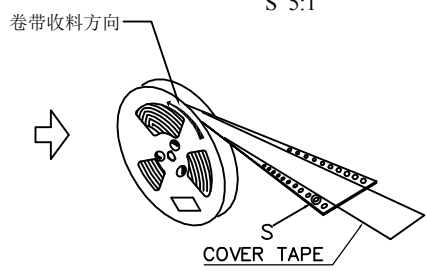
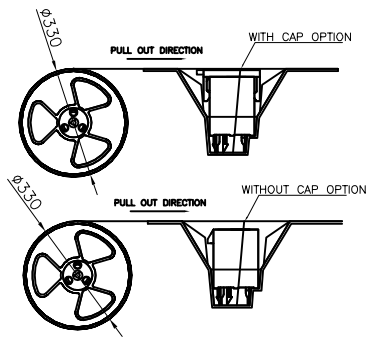
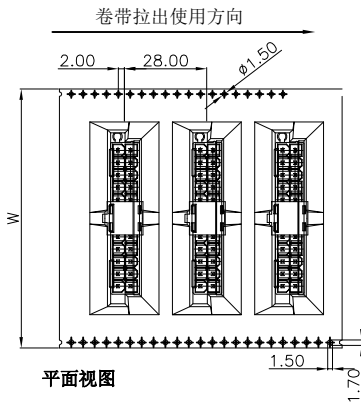

注:正对卷带,上方为圆孔,下方为U孔为正面
卷带/卷盘/上带材质: PS(黑色)/PS(蓝色)/PET(透明色)
剥离力标准:20~130g

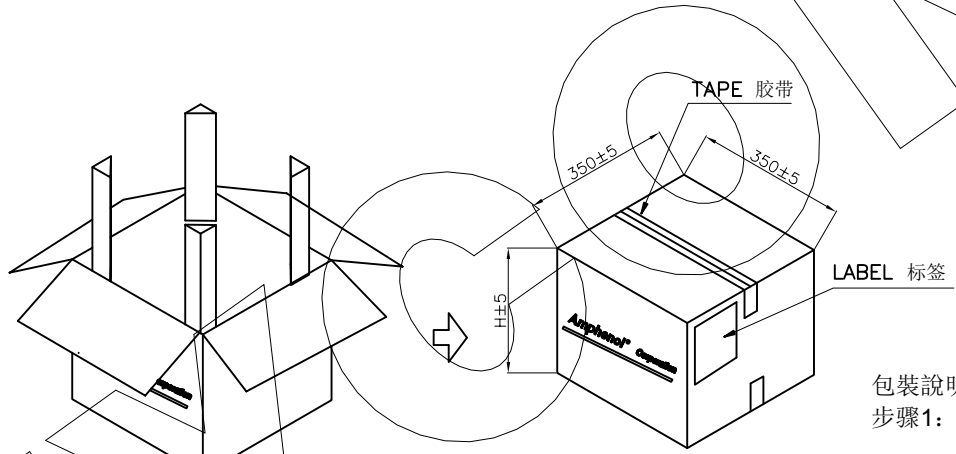

包装说明:
步骤1: 将检验好的成品Dip朝下放入REEL卷带内,每卷装100PCS,前后各空10PCS,每卷需贴上标签.
步骤2: 将2PCS干燥剂放入真空袋,
步骤3: 将卷盘装入真空袋,吸去真空.
步骤4: 叠好放入一个外箱,(箱内上、下各放1PCS隔板).
步骤5: 封箱贴好胶纸.
步骤6: 在外箱上侧面右上角贴上相关标签.
注意: 如客户有特殊要求,依客户要求包装.

PCS REEL	REELS CARTON	QUANTITY (PCS)	W	H	POS.
100	5	500	44.0	270	04
100	5	500			06
100	5	500			08
100	4	400	56.0	270	10
100	4	400			12
100	4	400			14
100	3	300	72.0	270	16
100	3	300			18
100	3	300			20
100	3	300	88.0	350	22
100	3	300			24

外箱: (L350xW350xH350mm)
外箱: (L350xW350xH270mm)

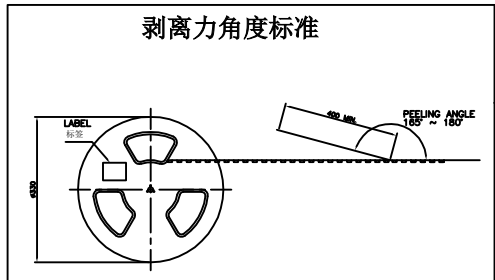

ANYCONN®
www.enkcom.com
TEL:+86(0)769 8904 9672
FAX:+86(0)769 8904 9671
E-MAIL:sales@anycom.tw

东莞市恩康电子科技有限公司
DONGGUAN ENKANG ELECTRONICS TECHNOLOGY CO.,LTD

TOLERANCE	DATE: 2023-04-20	TITLE: Mini Power PH4.20 HI2.8 180度 PH28.00mm卷带包装规范
ANGLE ±5°	DRAWN: JQSUN	PART NO: WFJD12XXXXXXXXDX19
X.XXX ±0.15	CHECKED:	
X.XX ±0.25	APPROVED:	
X.X ±0.35	PROJECTON	REV: A0
X. ±0.50		UNIT: mm
		SCALE: 1:1
		SIZE: A4
		PAGE: 1/1