

REVISION DATA		
REV	DESCRIPTION	DATE
A0	NEW DRAWING	2016-07-14

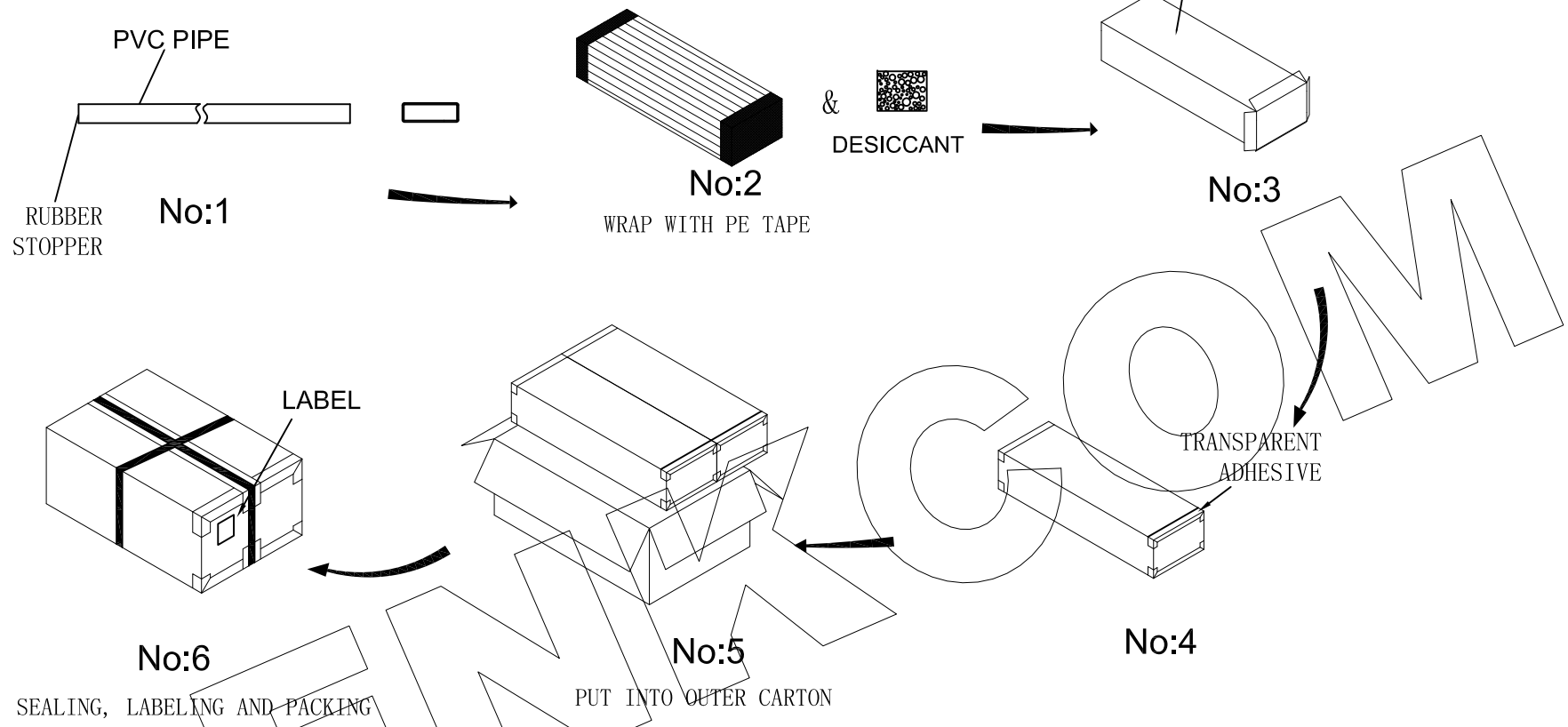

PACKAGE DESCRIPTION:
 STEP 1: PUT THE TESTED PRODUCT INTO THE PVC PIPE, AND THEN GLUE THE PVC PIPE PLUG AND SEAL
 STEP 2: WRAP THE PVC PIPE WITH PE FILM AND PUT IN DESICCANT
 STEP 3: PUT THE WRAPPED PVC PIPE INTO THE INNER BOX.
 STEP 4: SEAL THE INNER BOX WITH TRANSPARENT GLUE
 STEP 5: SEAL THE SEALED INNER CASE AND OUTER BOX.
 STEP 6: SEAL THE OUTER BOX WITH TRANSPARENT GLUE AND LABEL THE OUTER BOX. THEN BANDAGE TAKE A BANDAGE.

PART No.	PIPE/pcs	BOX/PIPE
BHXXXX12XXXXXXXXXX	XX	XXX

ENKCOM® 东莞市恩康电子科技有限公司
 DONGGUAN ENKANG ELECTRONICS TECHNOLOGY CO.,LTD

www.enkcom.com
 TEL:+86(0)769 8904 9672
 FAX:+86(0)769 8904 9671
 E-MAIL:sales@anycom.tw

TOLERANCE ANGLE ±5° X.XXX ±0.10 X.XX ±0.20 X.X ±0.30 X. ±0.50	DATE :	2020-09-17	TITLE:			
	DRAWN :	Songjun	PH2.00 Box Header-Pipe Packing			
	CHECKED :		PART NO: BHXXXX12XXXXXXXXXX			
	APPROVED :					
PROJECTON		REV: A0	UNIT: mm	SCALE: 1:1	SIZE: A4	PAGE: 1/1

REVISION DATA		
REV	DESCRIPTION	DATE
A0	NEW DRAWING	2020-09-26

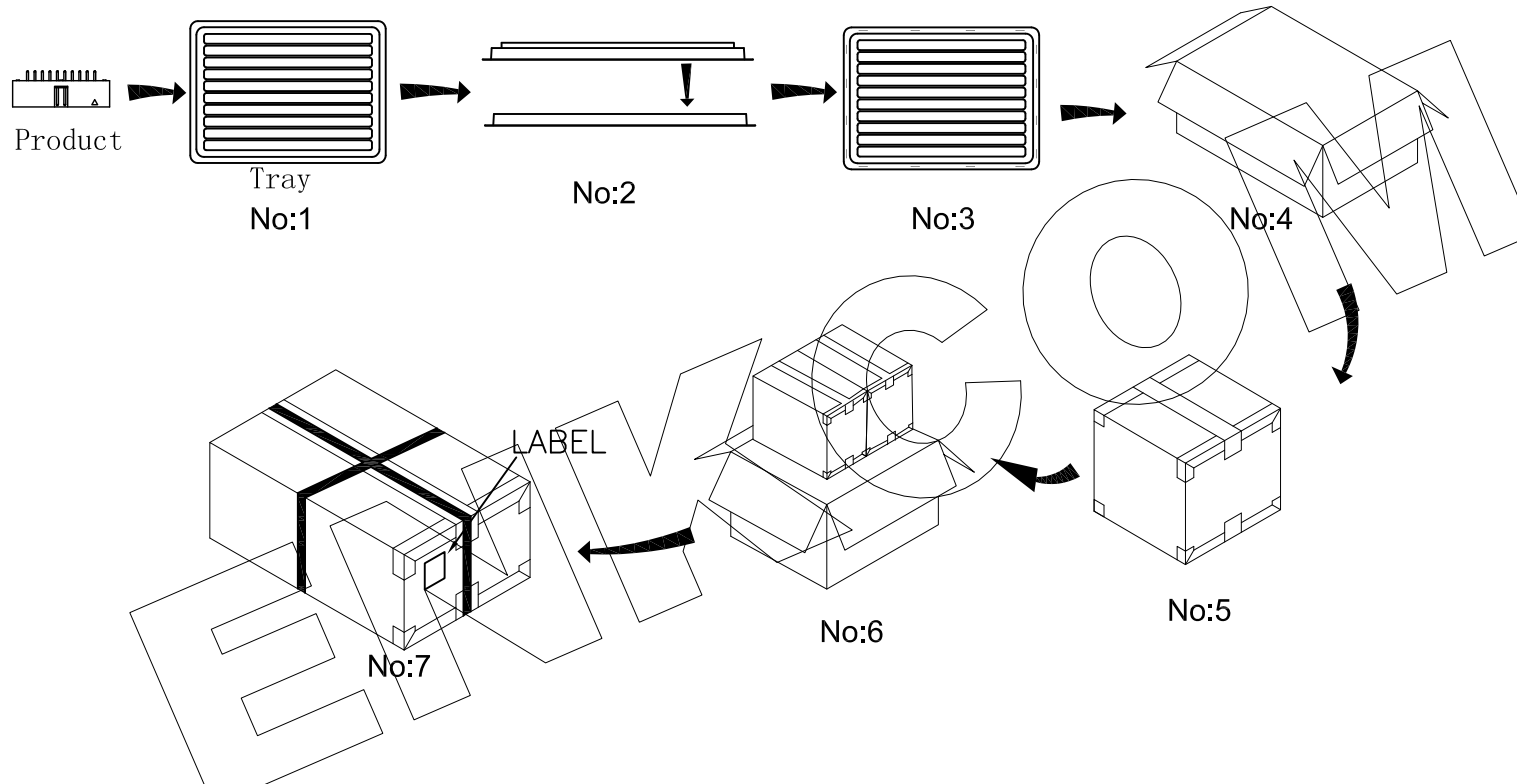

Package description:

- Step 1: put the inspected product dip foot upward into the vacuum disk
- Step 2: cover the vacuum disk with the upper cover
- Step 3: seal the vacuum disk with stapler.
- Step 4: put the vacuum disk with the product in the middle box
- Step 5: seal the middle box with transparent glue
- Step 6: seal the sealed middle case cover and outer box. Step 7: seal the outer box with transparent glue and label the outer box. Then bandage
- Take a bandage.

PART No.	Tray/pcs	Box/Tray
BHXXXX12XXXXXXXXXX	XX	XXX

ENKCOM® www.enkcom.com TEL:+86(0)769 8904 9672 FAX:+86(0)769 8904 9671 E-MAIL:sales@anycom.tw		东莞市恩康电子科技有限公司 DONGGUAN ENKANG ELECTRONICS TECHNOLOGY CO.,LTD	
 TOLERANCE ANGLE ±5° X.XXX ±0.10 X.XX ±0.20 X.X ±0.30 X. ±0.50 	DATE :	2020-09-26	TITLE:
	DRAWN :	Songjun	PH2.00 Box Header- Tray Packing
	CHECKED :		PART NO: BHXXXX12XXXXXXXXXX
	APPROVED :		
PROJECTON		REV: A0	UNIT: mm
		SCALE: 1:1	SIZE: A4
		PAGE: 1/1	