

REVISION DATA				
REV	ECN No.	DESCRIPTION	NAME	DATE
A0		NEW DRAWING	Songjun	2016-05-10

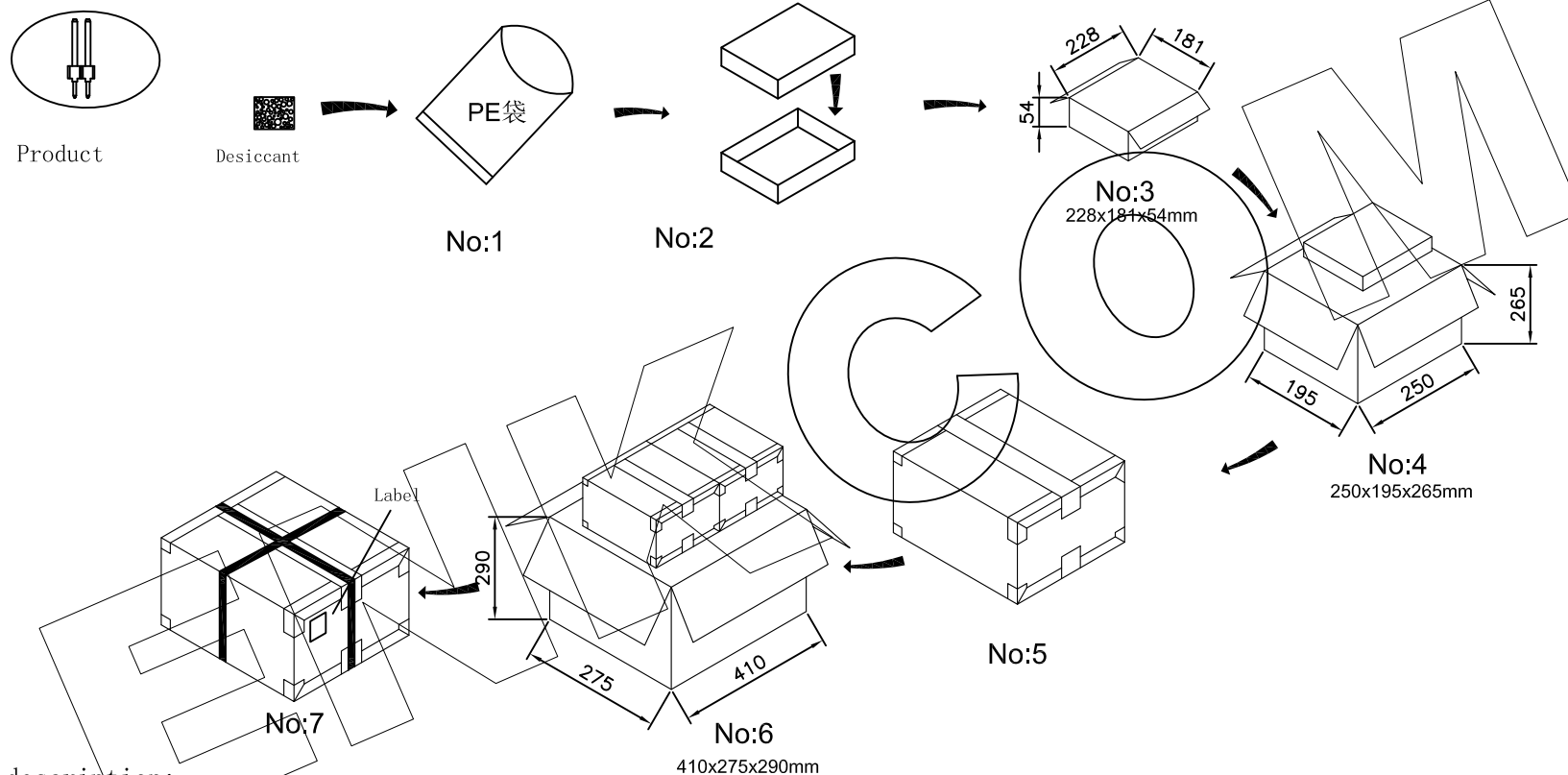

Package description:
 Step 1: put the inspected product into PE bag, put 1 pcs desiccant into PE bag, and heat shrink seal PE bag;
 Step 2: put the bagged products into the heaven and earth box, and seal them with transparent glue;
 Step 3: put the heaven and earth box of the product into the universal carton and seal it;
 Step 4: put the general carton with the product into the middle box;
 Step 5: seal the middle box with transparent glue;
 Step 6: seal the sealed middle case cover and outer box; step 7: seal the outer box with transparent glue and label it on the outer box, and then wrap it with bandage.

No.	PIN	BOX 1/pcs	BOX 2/PCS	BOX 3/PCS	BOX 4/PCS
P17911002XXDXXND001	1*2P	400	3200	12800	25600

ENKCOM® 东莞市恩康电子科技有限公司
 www.enkcom.com DONGGUAN ENKANG ELECTRONICS TECHNOLOGY CO.,LTD

TOLERANCE ANGLE ±5° X.XXX ±0.15 X.XX ±0.25 X.X ±0.40 X. ±0.50	DATE :	2018-09-25	TITLE:	PH2.54 H3.0 Pin Header-BAG PACKING					
	DRAWN :	Songjun	CHECKED :						
	APPROVED :		PART NO:	P17911XXXXDXXND001					
	PROJECTON		REV:	A0					
		UNIT:	mm	SCALE:	1:1	SIZE:	A4	PAGE:	1/1